

**AGENDA SEASIDE CITY COUNCIL MEETING
JANUARY 11, 2016 7:00 PM**

1. CALL TO ORDER
2. PLEDGE OF ALLEGIANCE
3. ROLL CALL
4. APPROVAL OF AGENDA
5. COMMENTS FROM STUDENT REPRESENTATIVE, Taylor Barnes
6. COMMENTS – PUBLIC
7. DECLARATION OF POTENTIAL CONFLICT OF INTEREST
8. CONSENT AGENDA
 - a) PAYMENT OF THE BILLS – \$835,391.07
 - b) APPROVAL OF MINUTES – DECEMBER 14, 2015 REGULAR MINUTES
9. UNFINISHED BUSINESS:
 - a) VACANCY – BUDGET COMMITTEE
10. NEW BUSINESS:
 - a) REPORT – AD HOC COMMITTEE CHURCH BUILDING, 1115 BROADWAY
 - b) PRESENTATION – CARTWRIGHT PARK OUTDOOR GYM (PACIFICA PROJECT), Berkley Posalski
 - c) PROPOSAL – NORTH HOLLADAY DRIVE CONSTRUCTION STAKING SURVEY
 - d) ORDINANCE 2016-01 – AN ORDINANCE OF THE CITY OF SEASIDE, OREGON, AMENDING CHAPTER 91 – CEMETERY REGULATIONS
 - > OPEN PUBLIC COMMENTS
 - > CLOSE PUBLIC COMMENTS
 - > COUNCIL COMMENTS
 - > MOTION FOR FIRST READING BY TITLE ONLY – ALL IN FAVOR AND OPPOSED
 - > MOTION FOR SECOND READING BY TITLE ONLY – ALL IN FAVOR AND OPPOSED
11. COMMENTS FROM THE COUNCIL
12. COMMENTS FROM THE CITY STAFF
13. ADJOURNMENT

Complete copies of the Current Council meeting Agenda Packets can be viewed at: *Seaside Public Library and Seaside City Hall. The Agendas and Minutes can be viewed on our website at www.cityofseaside.us.*

All meetings other than executive sessions are open to the public. When appropriate, any public member desiring to address the Council may be recognized by the presiding officer. Remarks are limited to the question under discussion except during public comment. This meeting is handicapped accessible. Please let us know at 503-738-5511 if you will need any special accommodation to participate in this meeting.

- CALL TO ORDER** The Regular meeting of the Seaside City Council was called to order at 7:00 PM by Council President Johnson.
- ROLL CALL** Present: Council President Don Johnson, Councilors Jay Barber, Seth Morrissey, Dana Phillips, and Tita Montero. .
- Absent: Mayor Don Larson and Councilor Randy Frank.
- Also Present: Mark Winstanley, City Manager; Russ Vandenberg, Convention Center & Visitors Bureau General Manager; Dave Ham, Seaside Police Chief; Dale McDowell, Public Works Director; Joey Daniels, Seaside Fire Chief; and Katherine Lacaze, Daily Astorian/Seaside Signal.
- AGENDA** Council President Johnson asked for approval of the agenda.
- Councilor Barber so moved with a second from Councilor Montero; carried unanimously. (Barber/Montero)
- REPRESENTATIVE** Taylor Barnes, Student Representative, stated in sports wrestling had a new coach this year and the team has done well in the first two meets. The swim team has also competed in two meets and have done very well. This season the swim team was young and had graduated a lot of seniors last year. The boy's basketball was two and one this season so far. The girl's basketball was also two and one for the season. Mr. Barnes further stated recently there was a student who was named Ms. Sweden, Meghan Sweet. The winter musical "You're in Town" will be holding auditions on Tuesday. The fall trimester just ended last week with two more trimesters to go. There was two weeks until winter break and this week at school was Holiday Week and was Harry Potter themed with games to go along with the week. The Annual Holiday Classic will be Thursday, Friday, and Saturday at the high school and Mr. Barnes invited everyone to come and check out the games.
- COMMENTS – PUBLIC** Tim Mancill, 755 N. Wahanna, Seaside, stated he owned a lawn maintenance business in Seaside and noticed there had been a gentleman that lived over on 7th and Lincoln had come in a few times and complained about back yard burning. Mr. Mancill further stated he took care of the yard at that house for the previous two owners as recently as four years ago and both residents that lived in that house got sick. Mr. Mancill believed there had been a meth lab ten or twelve years ago before the people had purchased the house. he had ripped the carpets out and had done a bunch of stuff and then sold it after six months to another gentleman which was a couple from Kirkland, Washington, and the house made the couple sick every time they stayed in it. The house went into foreclosure during the recession and the gentleman who owns it now purchased the house and now they have been getting sick. Mr. Mancill further stated the gentleman has been blaming the neighbors burning for making them sick and he wanted to clarify that he did not think the burning was the reason for the illness and he did not want to see burning regulations get enacted because of a guy getting sick and blaming the neighbor.
- Dennis Maier, 90529 Sunset Lake Road, Gearhart, stated he was here to propose to the city to approve recreational marijuana growing in the city limits. As it stands if the city voted against recreational marijuana growing the city would miss out on tax revenue that could benefit local infrastructures, schools, mental health programs, drug and alcohol education, and local police funding. The State of Oregon received \$3,500,000.00 in tax revenue the first day of recreational marijuana sales and the state predicted the recreational marijuana growing could reach four to five times that amount. If the community let this opportunity pass Seaside will still have medical growers able to grow in the city limits and not benefit from any of the tax incentives. Mr. Maier proposed the city approve recreational marijuana growing to help Seaside build a new high school out of the Tsunami Zone, help fund student scholarships, and help hire more police and fire for the community. This topic has been taboo in the past but his father was extremely sick and had to eat marijuana to make him feel better and the family has always accepted this.
- Tom Butori, 925 Avenue 'S', Seaside, stated he was speaking on the same topic. The issue he was concerned with was what would happen to the dispensaries that were already approved. If the medical dispensaries stopped and the recreation continued the black market would take over the sales and was something to think about for the future.
- CONFLICT** Council President Johnson asked whether any Councilor wished to declare a conflict of interest.
- No one declared a conflict of interest.

CONSENT AGENDA

Council President Johnson asked for a motion to approve the consent agenda.

Councilor Barber moved the approval of the consent agenda with a second from Councilor Phillips; carried unanimously. (Barber/Phillips)

**VACANCY –
BUDGET COMMITTEE**

Council President Johnson stated there was one vacancy on the Budget Committee. There were no applications received.

**VACANCY –
TRANSPORTATION
ADVISORY COMM.**

Council President Johnson stated there was one vacancy on the Transportation Advisory Commission. There was one applications received from David Posalski.

Councilor Montero proposed that we go ahead and appoint David Posalski to the Transportation Advisory Committee with a second from Councilor Morrisey. (Montero/Morrisey)

The term expiration for David Posalski would be October 1, 2016.

**PRESENTATION –
2014 – 2015 CITY OF
SEASIDE AUDIT**

Rick Proulx, Kern and Thompson CPA, stated for the year end of June 30, 2014, there was an audit performed of the financial statements in compliance with the City. Mr. Proulx further stated the audit was performed in accordance with general accepted auditing standards and rendered an opinion. The opinion on the financial statements for the City of Seaside was that the financial statements were fairly stated and all true in respects. The amounts and disclosures were proper and adequate and everything was recorded properly in the right year and the statements were suitable for the presentation and were available to the public.

Council President Johnson asked for comments from the Council and there were no comments. Council President Johnson asked for a motion to accept the audit.

Councilor Morrisey so moved we accept the audit with a second from Councilor Phillips; carried unanimously. (Morrisey/Phillips)

**REQUEST –
PURCHASE 1992 SPARTAN
FIRE ENGINE**

Joey Daniels, Seaside Fire Chief, stated the City of Seaside had received the new Pumper/Rescue Fire Truck from Spartan and would support selling the old 1992 Spartan Engine to Elsie Vinemapple R.F.P.D. in the amount of \$8,000.00. Elsie Vinemapple R.F.P.D is a mutual aid partner with Seaside Fire & Rescue and is unable to update their apparatus without getting used apparatus at a low cost.

Mike Wammack, Elsie Vinemapple R.F.P.D Chief, stated the Elsie Vinemapple Fire District was interested in the Seaside fire engine. The Elsie Fire District currently had 23 firefighters who operate out of three stations, runs about 300 calls a year and covers about 500 square miles. We have a mutual aid contract with Clatsop County and work regularly with the Seaside Fire Department. There was an operating budget of \$60,000.00 a year and any help that was received from other local fire districts makes a big difference in the outcomes of our calls and the lives that we touch. The district currently ran three engines ranging from the 1970s to early 1980s. The goal was to replace these engines with enclosed cab apparatus to improve the safety of the volunteers while riding. Receiving a truck like Seaside's would be a giant step toward reaching that goal.

Councilor Barber so moved the approval for the request of selling the old 1992 Spartan Engine to Elsie Vinemapple R.F.P.D., in the amount of \$8,000.00, with a second from Councilor Phillips; carried unanimously. (Barber/Phillips)

**PRESENTATION –
EARTHQUAKE AND
TSUNAMI PREPARED.**

Seaside High School Presentation by Taylor Barnes, Jesse Trott, and Whitney Westerholm – Earthquake and Tsunami Preparedness in the community. The presentation started with an earthquake and the Tsunami Siren with students getting down.

Whitney Westerholm stated the ABS as a student council made this video of the Seaside High School evacuation route and it does go in slow motion but the time was actual in the evacuation. (The video played as the students presented).

Jesse Trott stated the project was all about Tsunami Preparedness specifically focusing on the earthquake and tsunami that was supposed to hit the coast line from the southern tips of Canada to the very Northern tip of California. There will be information given about the Cascadia Subduction Zone or the Cascadia Fault Break or Cascadia Event and that was the event being presented. Ms. Trott further stated when this began most of us did not know that Seaside was a really unprepared community.

Ms. Westerholm stated practice at the high school was one evacuation per trimester. There were a lot of obstacles to face and there were bridges that had to be crossed to get to higher ground. A possible Cascadia Event would be 8.7 and the bridges would not be intact and would basically be mangled blocks of concrete. What was the next option to get across?

Taylor Barnes discussed the Cascadia Fault Break which was an enormous earthquake at 8.7 to 9.2. After the earthquake there would be a large tsunami and was predicted to be similar to the one that occurred in Japan which was a 9.0 earthquake? Mr. Barnes stated the tsunami that would hit was very survivable if you can get to higher ground.

Ms. Trott discussed Seaside, Gearhart, and Cannon Beach which were not in good shape. People could be left stranded without help for two to three weeks. It would take even longer for the communities to get back to normal. There was an OPB Clip that was presented.

Ms. Westerholm stated three of the schools were in the Cascadia Inundation Zone that is essentially anything underwater. Ms. Westerholm further discussed the Cascadia Inundation Zone.

Mr. Barnes presented pictures of Japan before the earthquake and after and Seaside was comparable to what happened in Japan and what was expected to happen. The high school was built in 1959 and had surpassed its capabilities in housing students and the building had a lot of issues. There were discussions regarding issues with the high school. A majority of the students would be trapped in the school and would not get out and would drown. The Seaside schools were not retrofitted for earthquakes and most likely would not be standing after.

Ms. Trott discussed the information regarding being prepared for an earthquake and how it should be discussed with family. New signs were put up throughout town for tsunami evacuations. Each classroom had emergency backpacks that would be grabbed. The City of Seaside has set up a tsunami supply barrel program and discussed the supplies that were in each barrel.

Mr. Taylor stated the event could happen 5 minutes from now or 500 years from now. This was important to understand the procedures that take place if an earthquake were to happen. The important thing was to not stop and get yourself to safety. There will be no time to help others.

Ms. Westerholm stated students that attended the school in a really risky location wanted to work at raising funds to relocate our four schools outside the inundation zone. This would be safe for students and could also act as an evacuation place. There was a discussion about raising funds for the schools. The story has been presented to other schools and relocating the schools was a big goal this year to raise funds.

The students shared their own personal story and then presented a blue ribbon to each person at the meeting and asked that each person share the student's story. There were fundraising ideas discussed. The students walked outside the inundation zone in 23-24 minutes.

PUBLIC HEARING

This was the duly advertised time and place to hold a public hearing regarding A Resolution Adopting and Appropriating Supplemental Budget Increases of Greater than 10% for the 2015-2016 City of Seaside Budget.

RESOLUTION #3857

A RESOLUTION ADOPTING AND APPROPRIATING SUPPLEMENTAL BUDGET INCREASES OF GREATER THAN 10% FOR THE 2015-2016 CITY OF SEASIDE BUDGET

Mark Winstanley, City Manager, explained the resolution would make adjustments to the beginning fund balances so they coincide with what the audit had for ending fund balances last year. This was a housekeeping resolution. A public hearing was required for the resolution.

Council President Johnson opened the public hearing.

There were no public comments and Council President Johnson closed the public hearing.

Council President Johnson asked for Council comments, there were no Council comments.

Council President Johnson asked for a motion.

Councilor Montero so moved to read by title only with a second from Councilor Morrisey; carried unanimously. (Montero/Morrisey)

Council President Johnson asked for a motion to adopt.

Councilor Barber moved that we adopt Resolution #3857 with a second from Councilor Montero; carried unanimously. (Barber/Montero)

RESOLUTION #3858

A RESOLUTION ADOPTING AND APPROPRIATING SUPPLEMENTAL BUDGET INCREASES AND REDUCTIONS OF LESS THAN 10% FOR THE 2015-2016 CITY OF SEASIDE BUDGET

Mr. Winstanley explained the resolution adopting and appropriating supplemental budget of less than ten percent. The majority of the budgets were increases and were not required to have a public hearing.

Council President Johnson asked for public comments, there were no public comments.

Council President Johnson asked for Council comments, there were no Council comments.

Council President Johnson asked for a motion.

Councilor Montero moved to read Resolution #3858 by title only with a second from Councilor Phillips; carried unanimously. (Montero/Phillips)

Council President Johnson asked for a motion to adopt.

Councilor Barber so moved with a second from Councilor Montero; carried unanimously. (Barber/Montero)

PUBLIC HEARING

This was the duly advertised time and place to hold a public hearing regarding A Resolution Adopting and Appropriating a Supplemental Budget Increase of Greater than 10 percent to the 2015-2016 Road District Budget

RESOLUTION #3859

A RESOLUTION ADOPTING AND APPROPRIATING A SUPPLEMENTAL BUDGET INCREASE OF GREATER THAN 10 PERCENT TO THE 2015-2016 ROAD DISTRICT BUDGET

Mr. Winstanley explained the resolution adopted and appropriated a supplemental budget of greater than ten percent and was for the Road District Budget. The Council acted as the governing body for the road district and was technically a separate governmental agency and was required to address separately.

Council President Johnson opened the public hearing.

There were no public comments and Council President Johnson closed the public hearing.

Council President Johnson asked for Council comments, there were no Council comments.

Council President Johnson asked for a motion.

Councilor Barber moved that we read by title only resolution #3859 with a second from Councilor Phillips; carried unanimously. (Barber/Phillips)

Council President Johnson asked for a motion to adopt.

Councilor Montero moved that we adopt Resolution #3859 with a second from Councilor Phillips; carried unanimously. (Montero/Phillips)

BID RESULTS – NORTH HOLLADAY IMPROVEMENT PROJECT

Dale McDowell, Public Works Director, stated the City advertised bids for the North Holladay Improvement Project 2015 on November 18, 2015, and opened bids on November 30, 2015. There were three bids received for the project which would be for the total rebuilding of North Holladay from 1st to 12th Avenue. Mr. McDowell further stated in general, this project consists of: Replacement of the existing sewer main, water main, force main and storm drainage along North Holladay. Re-connection of new and existing water/sewer services. 6 Install underground vaults and conduits for conversion of the existing overhead utilities (electrical, telephone, and cable) to underground utilities. New pavement and sidewalks will replace the existing surfaces. At the mandatory Pre-bid meeting — 8 Contractors (5 - General Contractors) were present. Three General Contractors provided sealed bids: Tapani Inc, - \$3,281,967.12; Big River Construction - \$3,599,264.00; and C&M Excavation - \$4,252,583.00. Staff recommended accepting Tapani Inc., bid of \$3,281,967.12.

Councilor Barber moved to approve the bid happily with a second from Councilor Phillips; carried unanimously. (Barber/Phillips)

APPROVAL – SPARTAN FIRE PUMPER/RESCUE

Chief Daniels stated the City of Seaside has received the new Pumper/Rescue from Spartan. The original bid was for \$475,377.00, after some change orders the final was \$463,786.00. Chief Daniels further stated the fire department was pleased with the Pumper/Rescue out and recommended the Mayor and City Council approves the payment to Spartan for the apparatus in the amount of \$463,786.00.

Council President Johnson asked for a motion to accept the truck.

Councilor Morrissey moved to pay Spartan for the new fire truck with a second from Councilor Phillips; carried unanimously. (Morrissey/Phillips)

**VACANCY –
LIBRARY BOARD**

Council President Johnson stated there was one vacancy on the Library Board with one term expiration from Russ Taggard who wished to be reappointed. Council President Johnson asked Council what they wished to do.

Councilor Barber moved that Russ Taggard is reappointed with a second from Councilor Montero; carried unanimously. (Barber/Montero)

The term expiration for Russ Taggard would be December 31, 2019.

**VACANCY –
BUILDING BOARD
OF APPEALS**

Council President Johnson stated there were two vacancies on the Building Board of Appeals with two term expirations from James O'Brien, and Christopher Rose.

Councilor Barber moved that James O'Brien and Christopher Rose are reappointed with a second from Councilor Montero; carried unanimously. (Barber/Montero)

The term expiration for James O'Brien, and Christopher Rose would be December 31, 2018.

**VACANCY –
TOURISM ADVISORY
COMMITTEE**

Council President Johnson stated there were two vacancies on the Tourism Advisory Committee with two term expirations from Keith Chandler, and Linda Wyss.

Councilor Barber moved that Keith Chandler and Linda Wyss are reappointed with a second from Councilor Montero; carried unanimously. (Barber/Montero)

The term expiration for Keith Chandler and Linda Wyss would be December 31, 2018.

COMMENTS – COUNCIL

Councilor Morrissey stated in the spirit of Tsunami Awareness if anyone hasn't yet seen the OPB Documentary on Tsunami Preparedness 'Unprepared' it was very good and he learned a lot from it.

Councilor Phillips stated she was very impressed with the student's presentation and on behalf of our student's safety and having a husband who was a school board chair move forward with trying to get the schools built. Councilor Phillips further stated if there was anything that Councilor Phillips or her husband Steve Phillips could do they would be more than happy to be involved. Councilor Phillips asked about selling the blue ribbons as a fund raiser.

Councilor Montero stated the presentation was impressive and she really liked the logo and the logo could be made into a sticker or t-shirts. Councilor Montero further stated it was the last Saturday of the Gingerbread Tea at the Seaside Museum and Taylor Barnes and his sister came and helped wash dishes.

Councilor Barber stated he was thinking when the presentation was being made about a great book that he read daily and there was a little verse that stated "A child shall lead them" and what we are seeing here is that our young people are leading the way for us to wake up to the reality that we live in. This presentation helps people to stop ignoring the reality.

Council President Johnson wished everyone a very Merry Christmas and a wonderful New Year. The next Council meeting will be next year.

COMMENTS – STAFF

None

ADJOURNMENT

The regular meeting adjourned at 8:07 PM.

Kim Jordan, Secretary

DON JOHNSON, COUNCIL PRESIDENT

SEASIDE BUDGET COMMITTEE

The Seaside Budget Committee meets publicly to review the budget documents as proposed by the budget officer. The budget committee receives the budget and budget message and provides an opportunity for the public to ask questions about and comment on the budget. The committee also approves a budget, and, if ad valorem property taxes are required, approves an amount or rate of tax for all funds that receive property taxes.

The budget committee is composed of the governing body and an equal number of electors appointed by the governing body. All members of the budget committee have equal authority. An elector is a qualified voter who has the right to vote for the adoption of any measure. If the governing body cannot find a sufficient number of electors who are willing to serve, those who are willing and the governing body become the budget committee.

Applicants for the Budget Committee need to be registered voters of the City of Seaside for at least one year prior to serving on the Committee. The appointive members of the budget committee cannot be officers, agents or employees of the local government. Spouses of officers, agents or employees of the local government are not barred from serving on the budget committee if they are qualified electors and not themselves officers, agents, or employees. Appointive members of the budget committee are appointed for three-year terms.

The committee shall elect a presiding officer from among the members at the first meeting. No member of the budget committee may receive any compensation for their services as a member of the committee.

COMMITTEE/COMMISSION APPOINTMENT

1. **Date Council Notified:** November 9, 2015

Name: Dale McDowell

Commission/Committee: Budget Committee

Resignation Date: McDowell – November 9, 2015

Term Expiration Date: McDowell – December 31, 2016

Wants to be considered again: McDowell – No

2. **Applicants:**

3. **Nominations:**

4. **Appointment:**



CITY of SEASIDE

OREGON'S
F A M O U S
A L L - Y E A R
R E S O R T

989 BROADWAY
SEASIDE, OREGON 97138
(503) 738-5511

BUDGET COMMITTEE

Term of Office: 3 years
Number of Members: 14 (Includes City Council)

<u>NAME</u>	<u>ADDRESS</u>	<u>PHONE</u>	<u>TERM EXPIRES</u>
LES MCNARY	1624 S. FRANKLIN	738-0759	12/31/2016
VACANCY			12/31/2016
JAMES SHIPLEY	284 ALPINE ST.	717-0392	12/31/2017
REBECCA BUCK	P O BOX 1152	738-3045	12/31/2017
NANCY MCCUNE	PO BOX 315	503-260-8905	12/31/2017
GENESEE DENNIS	770 AVENUE Q	503-791-1009	12/31/2018
GAYLE SPEAR	50 7 TH AVENUE	738-7942	12/31/2018

Berkley's Pacifica Project

Hello my name is Berkley Posalski,

I am an Eagle Scout, and a Senior at Seaside High School. For my Eagle Scout Project last May I designed, and assembled three stations for an outdoor gym at Cartwright Park at Seaside. I now want to complete my vision for this outdoor gym. For my Pacifica Project I will be adding three more stations to the gym for the public to use. These stations will allow people to have even more opportunities to exercise and give them more ways to exercise as well. I will design these stations keeping in mind some of the challenges we faced during the previous project. Along with the added stations, we will be expanding the concrete borders of the current stations to make the area around them more safe. Attached to this form is a few drawings for the upcoming project. I am sorry I could not make it to this meeting due to prearranged plans out of town.

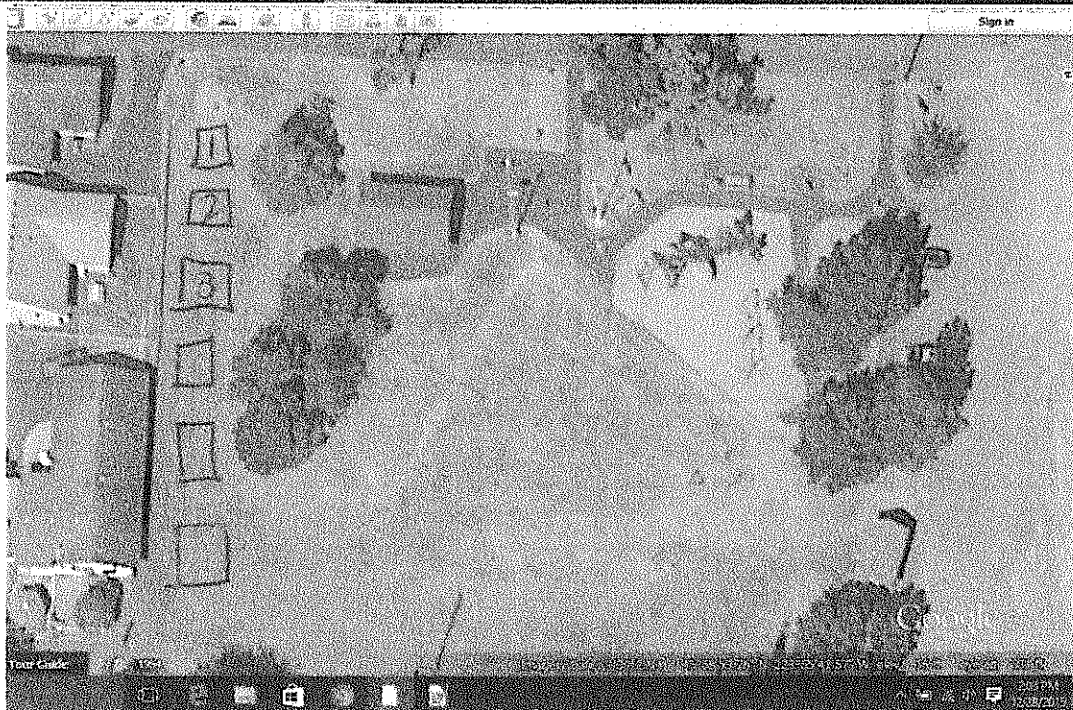

- 1 = situp station
- 2 = ropes
- 3 = pullup bars

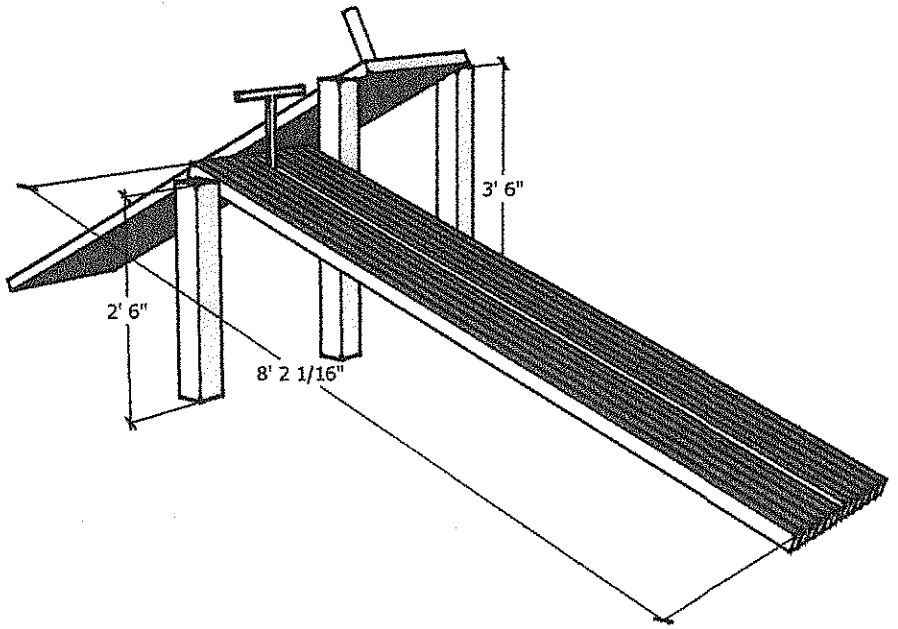

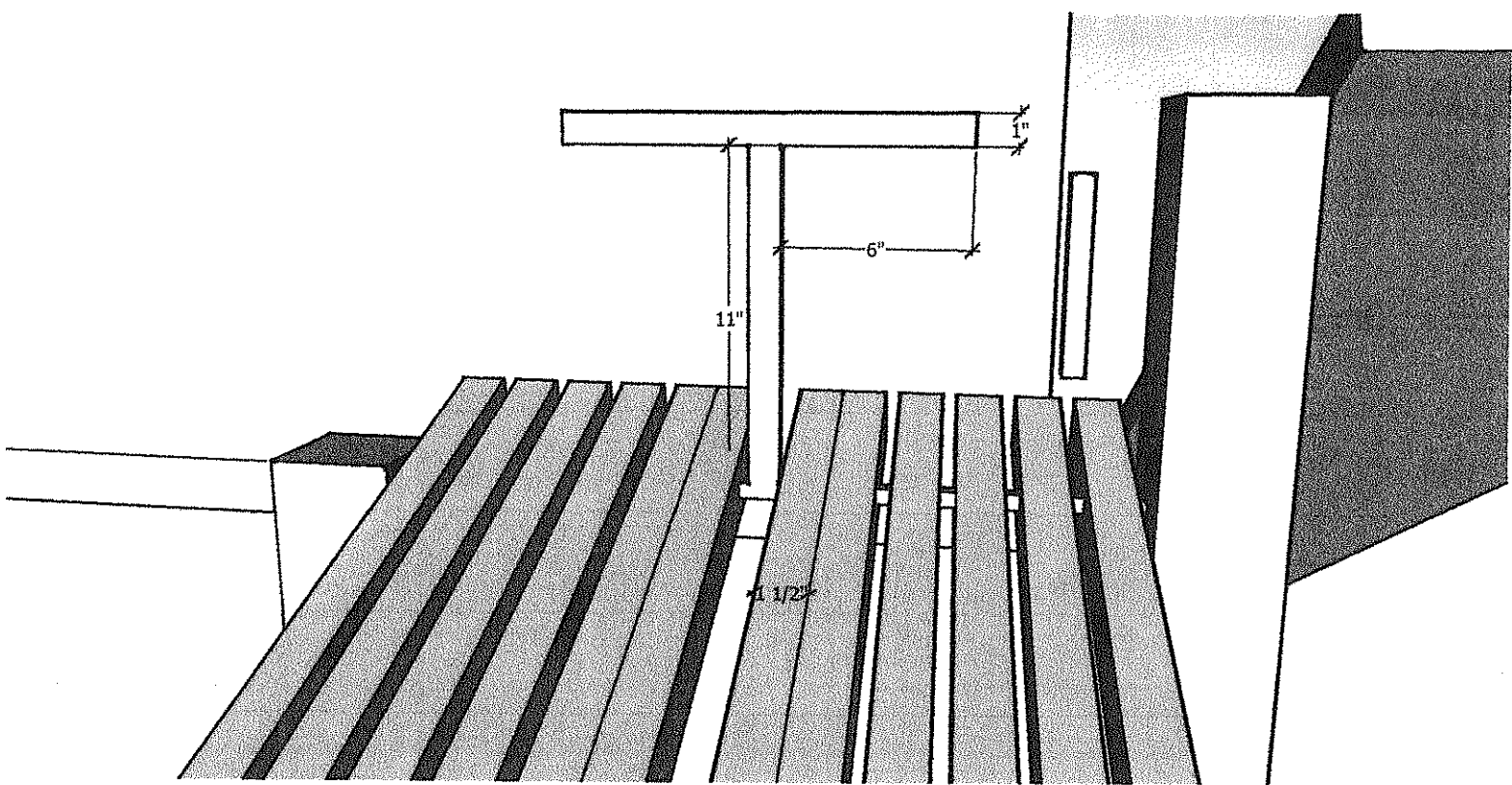

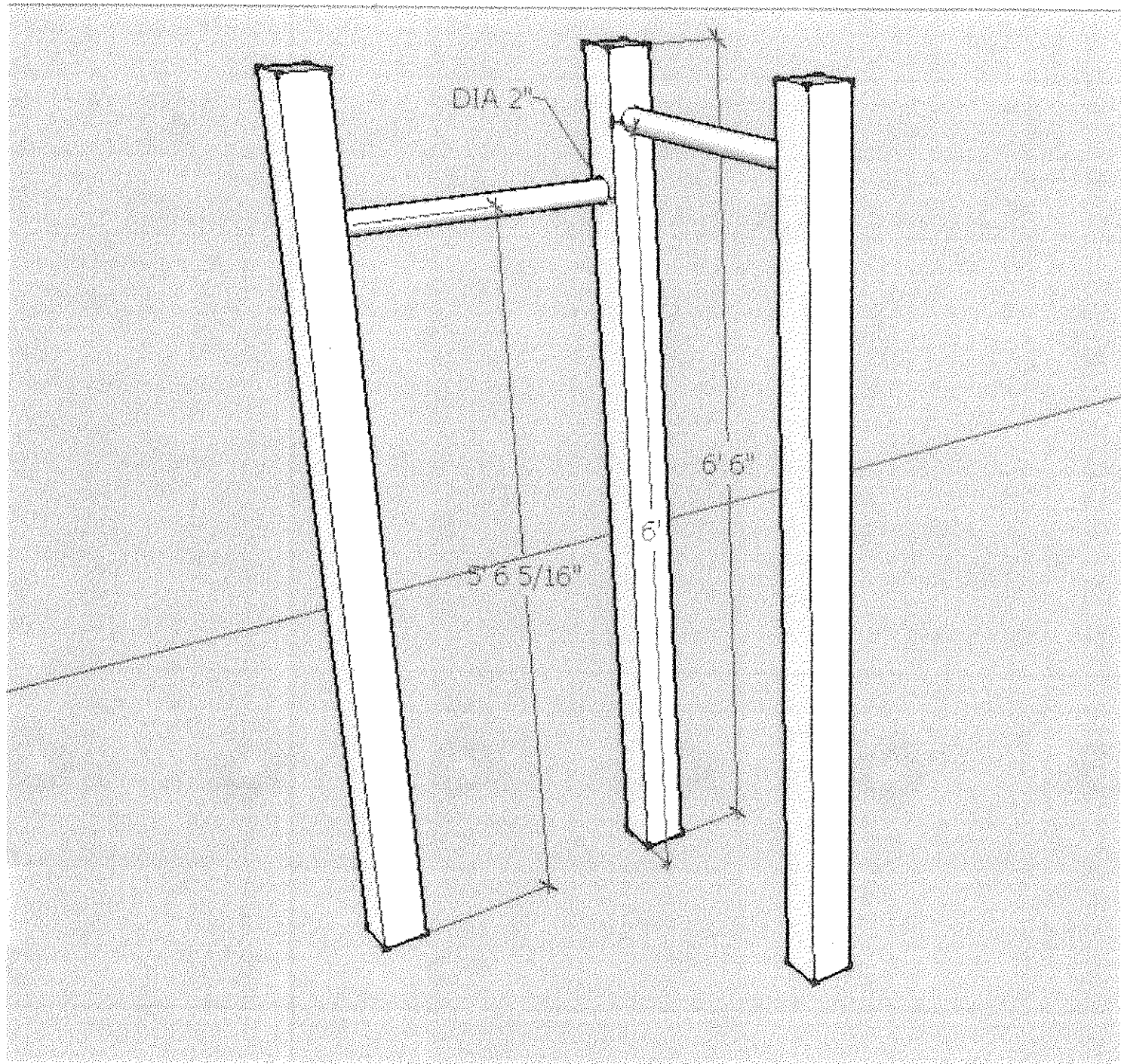

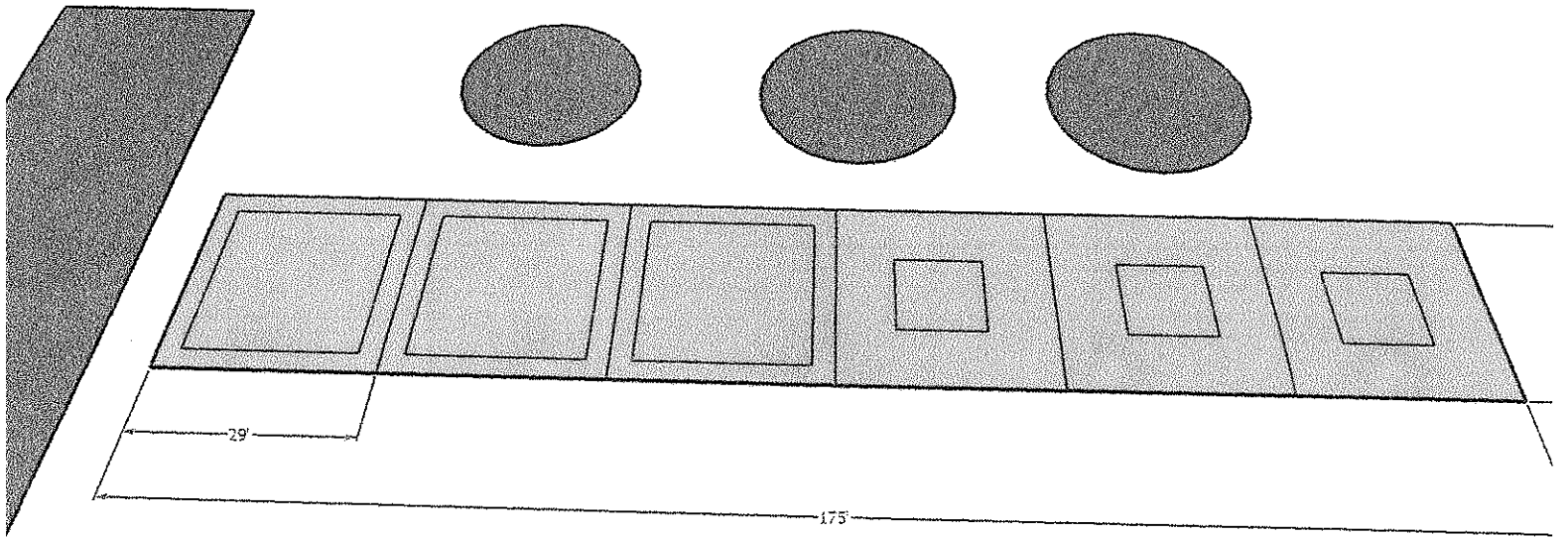



MEMO

From: Geoffrey Liljenwall, PE
To: The Honorable Mayor and City Council
Re: North Holladay 2015 – Construction Staking

January 6, 2016

This project is for providing construction staking for the North Holladay Project. In general, this project consists of:

- Construction staking for:
 - Sewer manholes
 - Sewer laterals
 - Storm manholes
 - Catch Basins
 - Curbs
 - ADA Ramps
 - Street 'bulb-outs'
 - Survey monuments
 - Construction/Material quantities
 - Road grades

The request was sent to: Otak-HLB and CKI. These are two local firms.

Otak was the only firm that provided a bid. CKI declined to submit a bid.

Otak Bid was for \$70,180

Staff recommends accepting Otak bid of \$70,180.



HammiGlobal Partner

4253-a highway 101 n | seaside, oregon 97138
503.738.3425 | fax 503.738.7455
www.otak.com

January 5, 2016

City of Seaside, Public Works
Geoffrey Liljenwall, City Engineer
1387 Avenue U
Seaside, OR 97138

Re: **Construction Staking Proposal, N Holladay Dr 1st to 12th Streets, Seaside Or.**

Dear Geoff:

We appreciate the opportunity to submit this proposal for professional surveying services for the North Holladay street project, 1st street to 12th streets. This proposal is based on your December 22, 2015 Request For Survey Proposals (RFP) for the Construction Staking Survey.

Scope of Work

Otak, Inc. proposes to provide one set of construction stakes as outlined in your proposal and the City Plans dated November 16, 2015. The five items listed on page 2 of the RFP are listed below with the cost as follows:

Item	Quantity	Units	Unit Cost
Gravity Sewer	1	LS	\$6,582.00
Storm	1	LS	\$13,271.00
Water	1	LS	\$9,495.00
Forced Sewer Main	1	I.S.	\$4,270.00
Misc. Staking	1	LS	\$36,562.00
Total:			\$70,180.00

For items listed in the RFP that will be performed on a Time and Material basis, Otak proposes to submit an estimate of fees and scope of work to the City for approval prior to proceeding with the work.

Maps will be prepared in Auto Cad Civil 3d, 2014 format, and Cut sheets will be provided within 2 days of the staked points.

Schedule

We are prepared to begin work within 2 days of your notice to proceed and upon receiving signed contract.

Fees

Otak, Inc. (Otak) proposes completing the above 5 work tasks on a Lump Sum basis for the **Total amount of \$70,180.00**. Additional work to be done on a Time and Material Basis, once authorized, will be at the rates listed on the attached hourly rate sheet. All in-house reimbursable costs, and any out-of-house direct costs, such as copies, reproductions, facsimiles, etc., are included in the contract amount and will be invoiced at cost plus ten (10) percent. Copies of direct expense vouchers are not provided with the invoices. Subconsultants will be invoiced at cost plus ten (10) percent.

Deliverables

One set of Construction Stakes for the 5 tasks listed in the RFP.

Conditions/Assumptions

Our scope of services and fees, as outlined herein, are based on the following assumptions and conditions:

1. Only those items specifically identified in the scope of work are included in the fees. If the project is materially changed, or if Client desires other professional services not already included in this Agreement, then additional compensation shall be paid to Otak, which shall be subject to negotiation by both parties. The terms of the Agreement shall apply to such additional services.
2. One set of construction stakes will be provided for the items listed in the RFP. Additional staking due to loss of previously staked points will be performed on a time and material basis once approved by the party responsible for payment.

Please call me at (503) 738-3425 or (503) 717-2427 (cell) if you have any questions. On behalf of Otak, we look forward to working with you.

Sincerely,
Otak, Inc.



Dale N. Barrett, PLS
Senior Associate

Enc: Otak Gearhart Office 2016 Hourly Rate Sheet

Otak Inc Hourly Rates for Gearhart Survey Staff, 2016

City of Seaside, Holladay Drive Staking Project

<u>Staff</u>	<u>Range of Hourly Rates</u>
Project Assistant	\$60 to \$65
PLS Sr Manager	\$120 to \$136
PLS	\$87 to \$102
Sr Survey Tech/ Party Chief	\$82 to \$87
Survey Tech II	\$60 to \$70
Engineering Tech II	\$68 to \$74

CITY OF SEASIDE
PUBLIC WORKS MEMORANDUM

TO: Professional Land Surveyors
FROM: Geoffrey Liljenwall PE, City Engineer
DATE: December 22, 2015
RE: North Holladay – 1st to 12th – Construction Staking

The City of Seaside is seeking proposals from qualified surveyors to assist the city in providing construction staking for the North Holladay Improvement Project – 1st to 12th. Tapani is the General Contractor for this project.

Proposal to be delivered to Public Works, by 2:00 PM on January 5, 2016 - to Geoffrey Liljenwall, City Engineer.

Attached Documents:

- Tapani Survey Staking Requests
- Itemized Bid List – showing quantities for structure items (sewer manholes, storm manholes, catch basins, and etc.)
- PDF of plans
- Original data points and CAD file - topographical survey

Services to include:

- Existing control and monuments shall be in state plane coordinates.
- Provide construction staking as per Tapani original request – See attached spreadsheet.
- Construction staking to be placed as per direction of OWNER – approval.
- Construction staking to be placed only once per requirement. CONTRACTOR is responsible for preservation of stakes and hubs.
- SURVEYOR to provide staking 'cut-sheets' and maps – hard copy and electronic to OWNER and CONTRACTOR.
- SURVEYOR to submit for review the above cut sheets/maps.
- SURVEYOR will tie in existing monuments that are found on site and that will be destroyed during construction. Replacing monument shall be done, if needed on a Time and Material basis.
- CONTRACTOR shall provide 5 business day advance notice for all staking requirements. This can be modified by agreement by OWNER, CONTRACTOR, and SURVEYOR. Intent is to provide time for calculations and staking.
- Verify ENGINEERS (city design) AutoCAD Civil3D surface – this to be used in calculation of construction quantities.
- Calculate Construction quantities – using existing surface and CONTRACTOR final graded surface:
 - Sub-base
 - Base
 - This will be on a time and material basis – separate from the LUMP SUMS that are Tapani construction staking requirements.
- Verify ENGINEERS grades in construction of the concrete curb and gutter. Note that this site is extremely flat – most concrete gutters will be at 0.5 % grade.

North Holladay – 1st to 12th – Tapani Construction Staking
2 of 2

Additional requirements:

- Duration of Contract – Substantial construction for the general contractor is May 27, 2015.
- Provide hourly rate for additional services.
- Walk-thru is available on as needed.
- Traffic Control is responsibility of the surveyor.
- Data to be submitted via CD-ROM.
 - Data structure to be discussed with Engineer.

Deliverables

- Copy of Field Notes
- Copy of Points files
- Copy of description for points
- AutoCAD drawing
 - All points in drawing
 - Layer management – to be determined
 - Surface generated in AutoCAD, exported as XML file.
 - AutoCAD version 2007 and newer
- Hard Copies of the above

Schedule of Contract Prices

	Quantity	Units	Unit Cost
Gravity Sewer	1	LS	
Storm	1	LS	
Water	1	LS	
Forced Sewer Main	1	LS	
Misc. Staking	1	LS	
		TOTAL	

Survey Needs - North Holladay Improvement 2015

Gravity Sewer

Description	Actual	Offset	Offset	Intervals	Out Of MH	Out Of MH
Man holes	NO	10'	15'	Each		
Sewer Main	NO	15'		50'	15'	25'
Lateral Tee's	NO	15'		Each		

Storm

Description	Actual	Offset	Offset	Intervals
Catch Basins	CL	5'	10'	Each
Curb Stakes	10' Each side of CL of CB @ face of curb			At Each CB
Man Holes	YES	10'	15'	Each
Storm Main	NO	15'		50'

Water

Description	Actual	Offset	Offset	Intervals
Water Main	NO	15'		50'
Tie Ins To Existing Main	YES	10'	15'	Each
Services	Right Of Way			Each
Tee Connections	NO	15'		Each
Hydrants	NO	10' With FG elevations	15' With FG elevations	Each

Forced Sewer Main

Description	Actual	Offset	Offset	Intervals
Forced Main	NO	15'		50'
Tie Ins	YES	15'		Each
Bends	YES	15'		Each

Misc. Staking

Description	Actual	Offset	Offset	Intervals
TFC	NO	3'		25'
Full Curb Radius's	NO	3'		
Driveway Approaches	CL of Driveway	3'		Each
ADA Ramps	CL of ADA	3'		Each
Street Lights	YES			Each
Junction Boxes	CL of box			Each
Peds.	YES			Each
Electrical Tie In Locations	YES			Each
Limits of demo - construction limits	YES			Each
Site Cal. Bench marks	YES			3 EA
Blue Tops for FG rock	YES			50'

Note : All survey stakes to have elevations & Stationing on back of the stakes.

ORDINANCE NO. 2016-01
AN ORDINANCE OF THE CITY OF SEASIDE, OREGON, AMENDING
CHAPTER 91 OF THE SEASIDE CODE OF ORDINANCES REGARDING
EVERGREEN CEMETERY REGULATIONS

THE CITY OF SEASIDE ORDAINS AS FOLLOWS:

SECTION 1. Chapter 91.07 DECENT OF PLOT. is amended to read as follows.
91.07 DECENT OF PLOT.

Upon the death of the owner, unless he has disposed of the plot either by specific direction in his will, or by a written declaration of reservation, filed in the office of the ~~City Auditor~~ City Manager, if no interment has been made in a plot, the plot descends to the heirs at law of the owner, subject to the rights of the surviving spouse.

SECTION 2. Chapter 91.09 DISINTERMENTS AND REMOVALS. is amended to read as follows:
91.09 DISINTERMENTS AND REMOVALS.

Disinterments and removals may be made with the written consent of the ~~Superintendent~~ Public Works Director, surviving spouse, the surviving parents of a child or unmarried person, other persons who have the legal right to order disinterment, and the plot owner, provided all the requirements of the laws of the State of Oregon, ordinances of the city, and the rules and regulations of the cemetery are complied with. Failure to comply with the conditions stated herein, or any other good and sufficient reason, shall be full authority for the ~~Superintendent~~ Public Works Director to postpone or deny such disinterment and removal.

SECTION 3. Chapter 91.13 PLOTS SOLD BACK TO THE CITY. is amended to read as follows:
91.13 PLOTS SOLD BACK TO CITY

In the event the owner of a plot decides not to utilize a plot purchased after October 1, 1985, it may sold back to the City at ~~90%~~ 80% of the purchase price. Such a request for city purchase must be in writing.

SECTION 4. Chapter 91.14 PURCHASE PRICE. is amended to read as follows:
91.14 PURCHASE PRICE

The city shall charge ~~\$200~~ \$500 for each lot until changed by future ordinance of the City Council.

ADOPTED by the City Council of the City of Seaside on this ___ day of _____, 2016 by the following roll call vote:

YEAS:
NAYS:
ABSTAIN:
ABSENT:

SUBMITTED to and APPROVED by the Mayor on this ___ day of _____, 2016.

Don Larson, Mayor

ATTEST:

Mark J. Winstanley, City Manager